

ITEM NO.	Number	Revision	Description	QTY.
1	SM-1293	01	MP1200 STAND TOP	1
2	SM-1294	01	MP1200 STAND LEG	4
3	SM-1292	01	MP1200 MACHINE BRKT R	1
4	SM-1291	01	MP1200 MACHINE BRKT L	1
5	MC 806MP10230	01	MP 1200 MIST COLLECTOR	1

REVISIONS			
REVISION	NOTES	DATE	AUTHOR
1		1/24/2017	

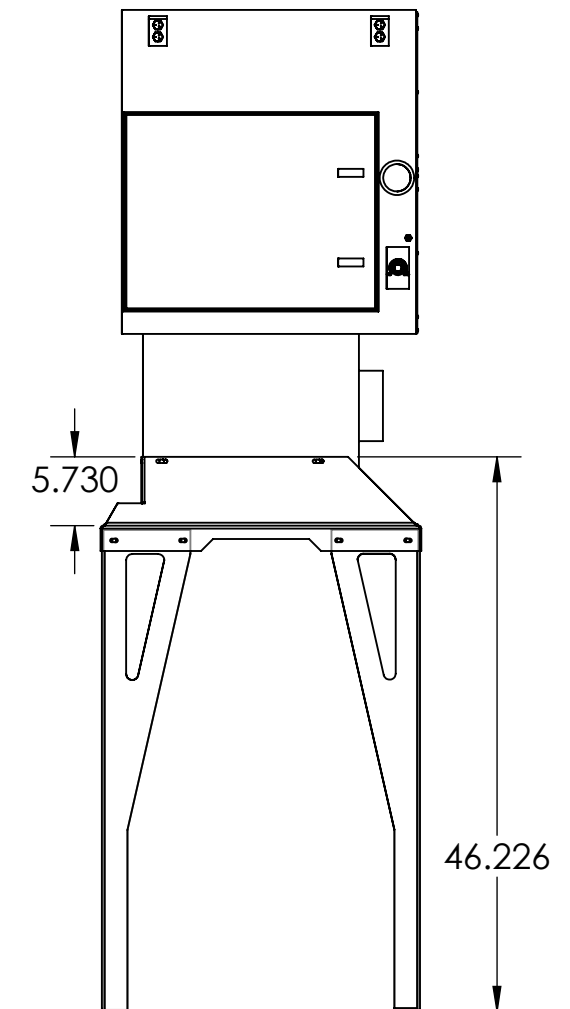
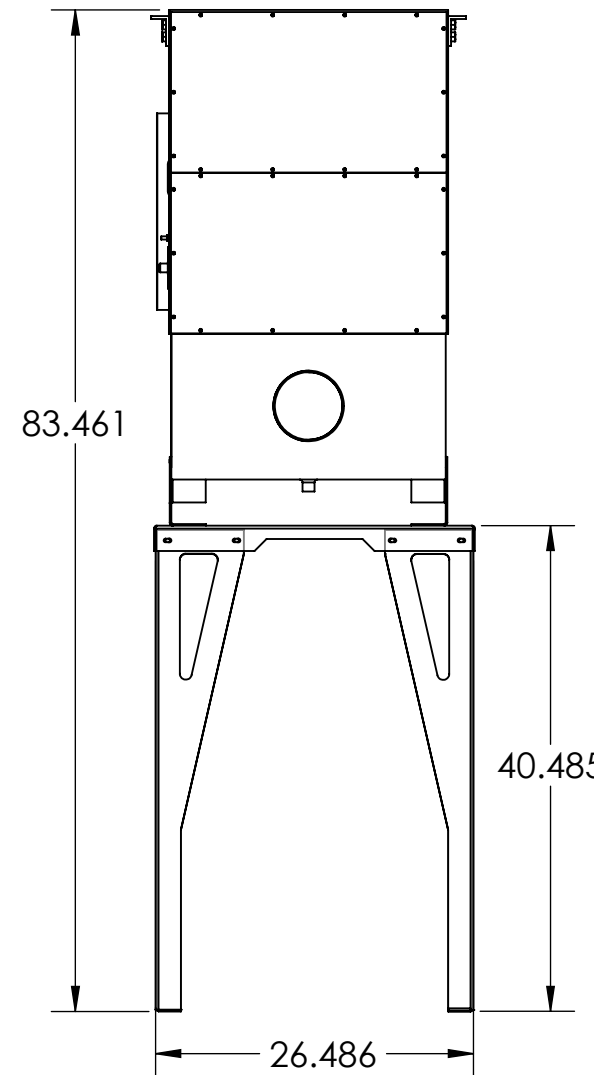
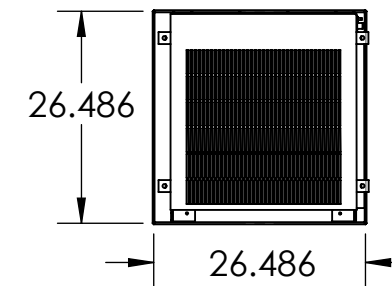
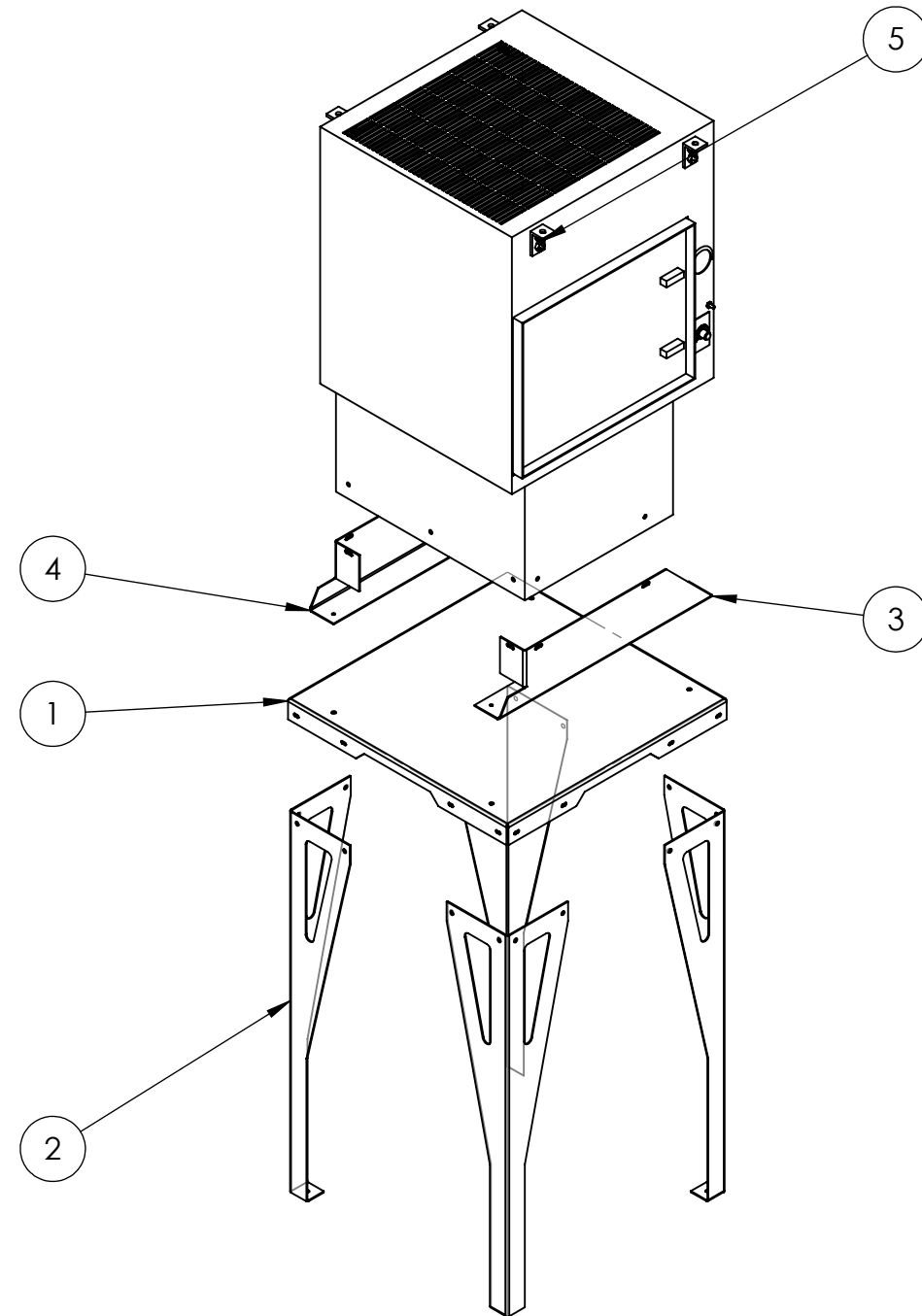

	MATERIAL SEE PARTS	UNLESS OTHERWISE SPECIFIED: DIMENSIONS ARE IN INCHES TOLERANCES: FRACTIONAL ±1/64 ANGULAR: MACH ±.5° BEND ±.5° TWO PLACE DECIMAL ±.010 THREE PLACE DECIMAL ±.005	COMMENTS: THIS DRAWING CONTAINS PROPRIETARY INFORMATION. DO NOT COPY. ALL RIGHTS RESERVED.	NAME	DATE	TITLE: MP1200 STAND BRKT ASSM	SIZE	DWG. NO.	REV
	FINISH SEE PARTS			34 BRADLEY PARK RD EAST GRANBY, CT 06026 1-877-689-1860	DRAWN 1/14/2020		CHECKED	B	SM-1296
DO NOT SCALE DRAWING						SCALE: 1:24		WEIGHT: 104.368 SHEET 1 OF 1	